

REVISIONS			
REV	DESCRIPTION	DATE	APPROVED
--	--	--	--

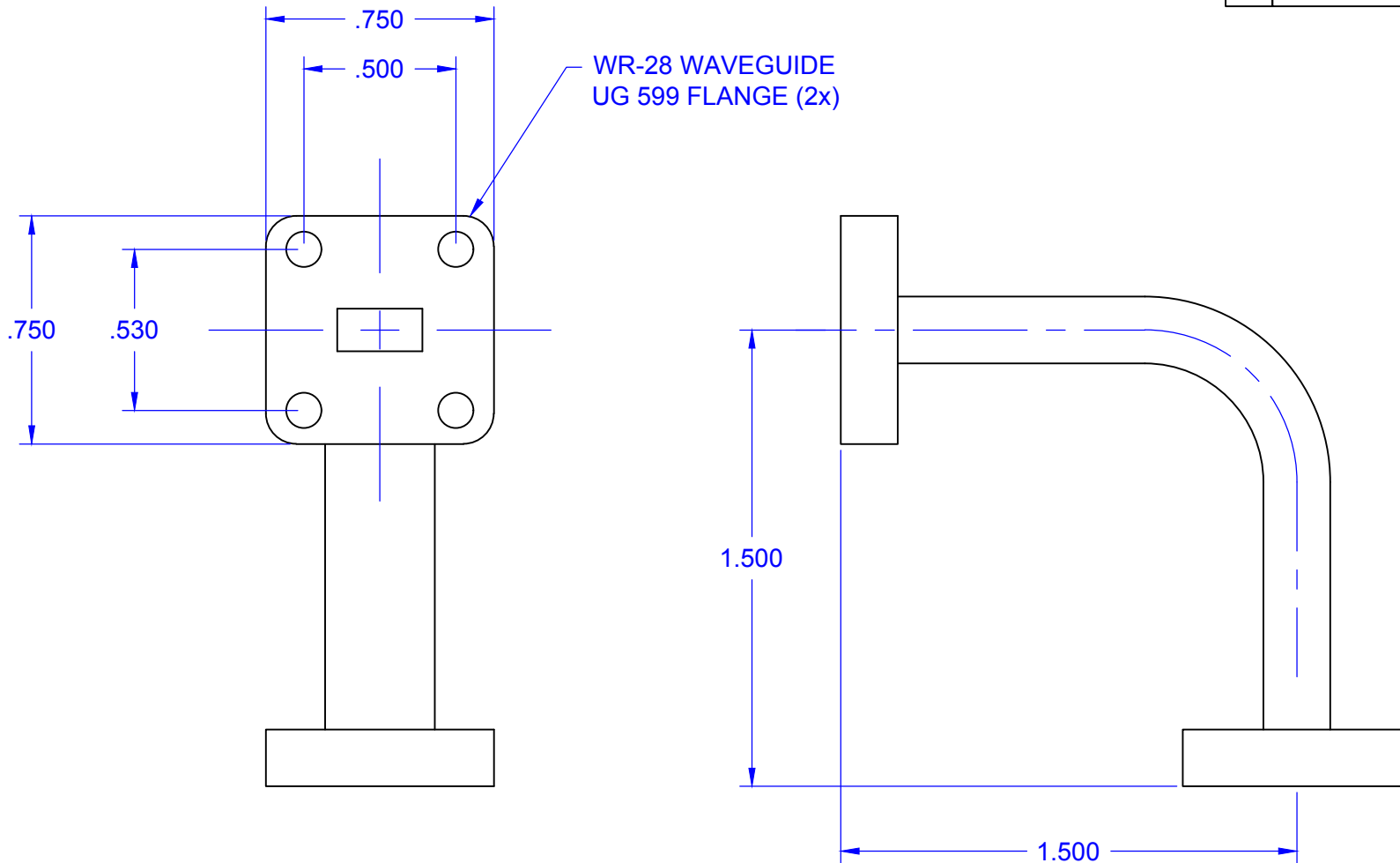

QTY	PART NUMBER	OUTLINE		DESCRIPTION	ITEM
UNLESS OTHERWISE SPECIFIED ALL SURFACES $\sqrt{32}$		 THIRD ANGLE PROJECTION	Mi-Wave Millimeter Products Inc.		
DIMENSIONS ARE IN INCHES TOLERANCES ARE: DECIMALS: .1234 +/- .0005 .123 +/- .005 .12 +/- .01 ANGLES: +/- .5 DEGREES			TITLE 660A/599 E-PLANE BEND OUTLINE		
ALL THREADS TO BE 2A OR 2B		DATE: 7/15/2010			
REF DWG# --		SHEET NO.	OF	SIZE	DWG NO
ORIGINAL DWG# 20181		1	1	A	20304